

PRODUCT INFORMATION PACKET



Model No: 324TSHFS19007AN

Catalog No: 811562.00

.40HP..3550RPM.324.TEFC.V.3PH.60HZ.CONT.40C.1.15SF.RIGID.324TSHFS19007AN.....IEEE-841.NOT.....

IEEE 841



Regal and Leeson are trademarks of Regal Beloit Corporation or one of its affiliated companies.

©2018 Regal Beloit Corporation, All Rights Reserved. MC017097E





Nameplate Specifications

Output HP	40 Hp	Output KW	30.0 kW
Frequency	60 Hz	Voltage	460 V
Current	47.0 A	Speed	3545 rpm
Service Factor	1.15	Phase	3
Efficiency	93.6 %	Duty	Continuous
Insulation Class	F	Design Code	B
KVA Code	G	Frame	324TS
Enclosure	Totally Enclosed Fan Cooled	Overload Protector	No
Ambient Temperature	40 °C	Drive End Bearing Size	312
Opp Drive End Bearing Size	311	UL	Recognized
CSA	Y	CE	Y
IP Code	56		

Technical Specifications

Electrical Type	Squirrel Cage Inverter Rated	Starting Method	Line Or Inverter
Poles	2	Rotation	Reversible
Mounting	Rigid base	Motor Orientation	HORIZONTAL
Drive End Bearing	BALL	Opp Drive End Bearing	BALL
Frame Material	Cast Iron	Shaft Type	TS
Overall Length	27.37 in	Frame Length	11.50 in
Shaft Diameter	1.875 in	Shaft Extension	3.75 in
Assembly/Box Mounting	F1/F2 CAPABLE		
Outline Drawing	B-SS301080LE-1150	Connection Diagram	A-EE7300U-LE

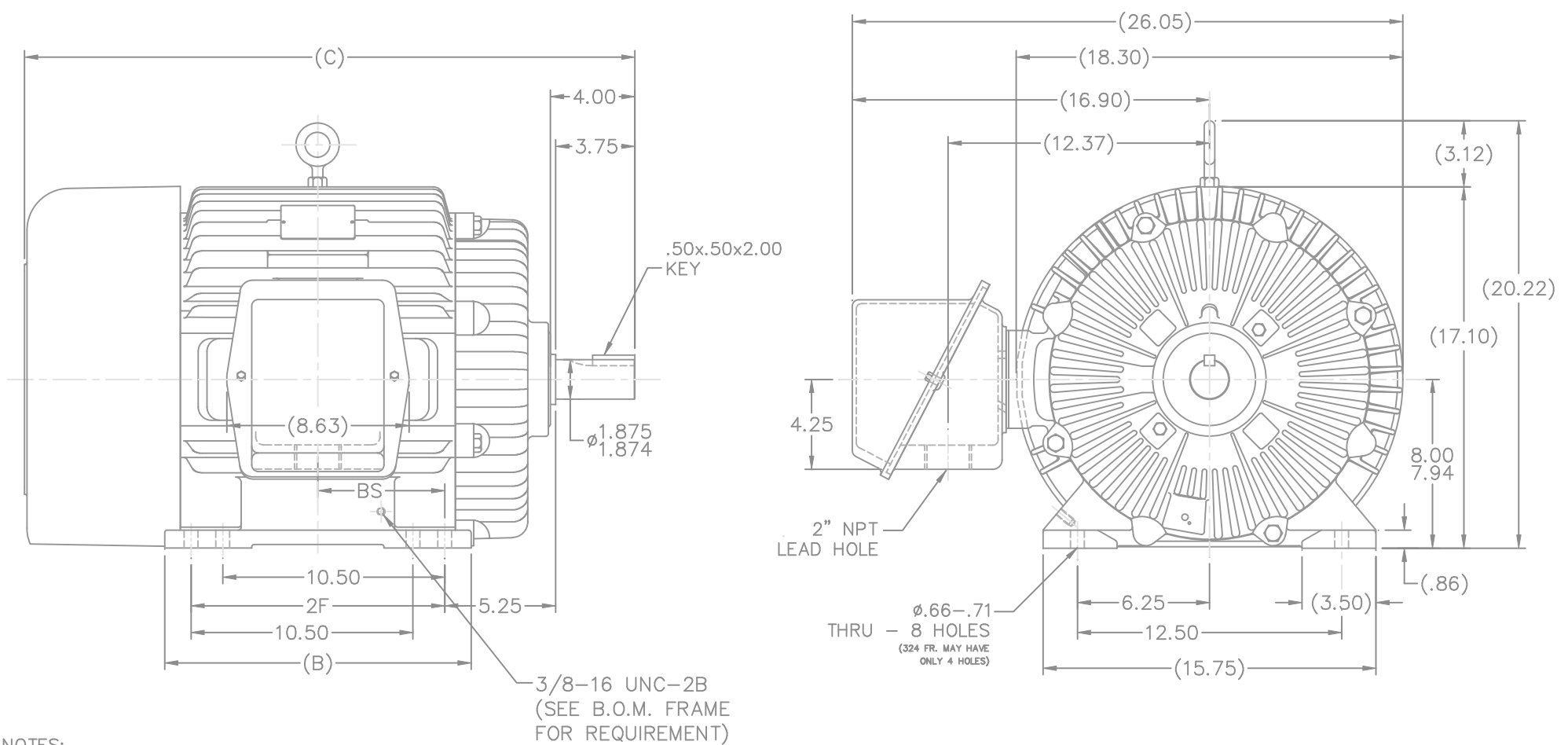

- NOTES:
 1. BOX CAN BE ROTATED IN 90° STEPS.
 2. BOX CAN BE MOUNTED ON OPPOSITE SIDE BY REMOVING BRACKETS AND TURNING FRAME 180°.
 3. NAMEPLATE TO BE READ FROM CONDUIT BOX SIDE OF MOTOR.

DASH	FR.	C	B	BS	2F
1150	324TS	27.37	13.00	5.25	10.50
1300	324/6TS	28.87	14.50	6.00	12.00

NO.		REVISION	BY & DATE	CHK	ANG	±7'30"	FINISH	 ELECTRIC MOTORS GEARMOTORS AND DRIVES		DRAWN	RWR 10-29-2008			
				DEC.	INCHES				CHK	ML 10-29-2008				
				.X	±.1				APPD	DR 10-29-2008				
				.XX	±.03		TITLE OUTLINE		SCALE	1=5				
				.XXX	±.005		320TS FRAME -TEFC		REF	B-SS301080				
				.XXX	±.0005		MAT'L		FMF	MU87713				
				THIS DRAWING IN DESIGN AND DETAIL IS OUR PROPERTY AND MUST NOT BE USED EXCEPT IN CONNECTION WITH OUR WORK ALL RIGHTS OF DESIGN AND INVENTION ARE RESERVED THIS IS AN ELECTRONICALLY GENERATED DOCUMENT - DO NOT SCALE THIS PRINT			RFP	10-29-2008	CAD FILE	SS301080LE	SIZE	DRAWING NO.	PAGE 1 OF 1	REV.
				DIST	LB				B	SS301080LE				

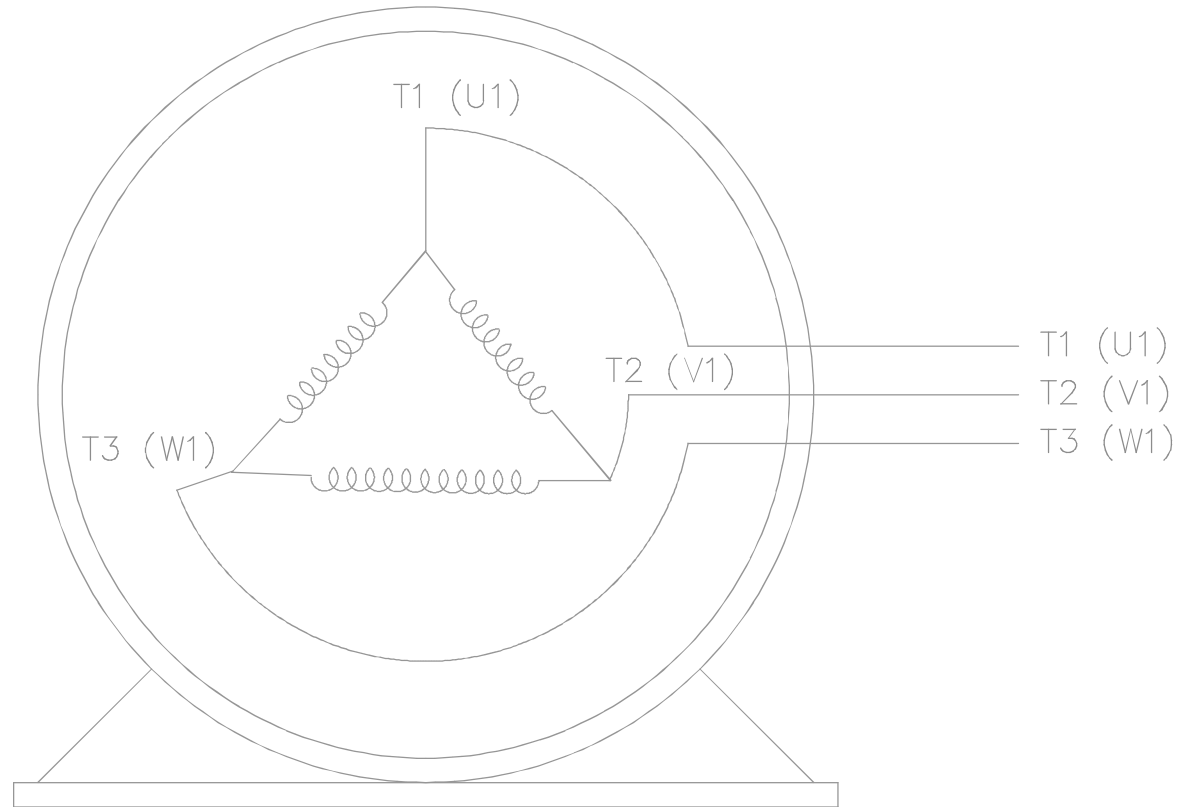

VIEW OF TERMINAL END

IF MOTOR HAS MULTIPLE
T'S PER LEAD CONNECT
TOGETHER LIKE T'S

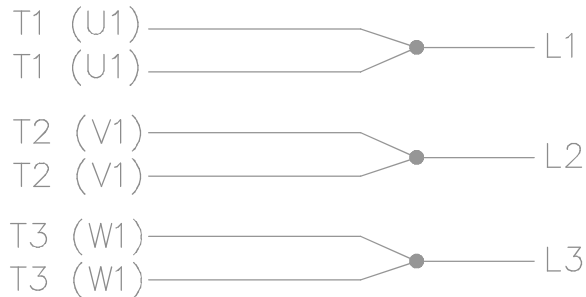

			TOLERANCES UNLESS SPECIFIED		 ELECTRIC MOTORS GEARMOTORS AND DRIVES	DRAWN KL 03-24-2003			
			DEC.	INCHES		CHK GFH 03-24-2003	APPD JES 03-24-2003		
			.X	± -	TITLE CONNECTION DIAGRAM 3Ø SINGLE VOLTAGE MAT'L. FINISH	SCALE 1=1	REF		
			.XX	± -		FMF	PREV		
			.XXX	± -					
			.XXXX	± -					
1	NEW DRAWING	MU45909	KL	03-24-2003					
NO.	REVISION	BY & DATE	CHK	ANG	± -	FINISH	PREV		
THIS DRAWING IN DESIGN AND DETAIL IS OUR PROPERTY AND MUST NOT BE USED EXCEPT IN CONNECTION WITH OUR WORK ALL RIGHTS OF DESIGN AND INVENTION ARE RESERVED THIS IS AN ELECTRONICALLY GENERATED DOCUMENT - DO NOT SCALE THIS PRINT			RFP	CAD FILE EE7300U-LE		SIZE A	DRAWING NO. EE7300U-LE	PAGE OF 1	REV. 1
			DIST	WA					



Motor Load Data									
Load	0%	25%	50%	75%	100%	115%	125%	LR	
Current (Amps)	14.7	18.5	26.0	35.5	47.0	53.0	54.5	275	
Torque (ft-lb)	0.00	14.5	29.5	44.0	59.5	68.5	74.5	91.5	
HPM	3600	3590	3575	3560	3545	3540	3530	0	
Efficiency (%)		87.5	92.4	93.6	93.6	93.6	93.0		
P.F. (%)	9.3	56.0	76.0	83.0	85.0	86.0	86.5	29.0	

Motor Speed Data						Information Block																					
LR	Pull-Up	BD	Rated	Idle		HP	Sync. RPM	Frame	Enclosure	Construction	Voltage	Frequency	Design	LR Code letter	Service Factor	Temp Rise @ FL	Duty	Ambient	Elevation	Rotor/Shaft wk ²	Ref Wdg	Sound Pressure @ 1M	VFD Rating	Outline Dwg	Conn. Diag	Additional Specifications:	
0	1800	3300	3545	3600		40.0	3600	324	TEFC	TFN	460	60	B	G	1.15	60	CONT	40	1,000	4.9	NONE	72	CONSTANT 20:1	B-SS301080LE-1150	A-EE7300U-1E		
275	248	172	47.0	14.7																							
Torque (ft-lb)	91.5	82.0	157	59.5	0.00																						

